



# WDM120TX

## Heavy-Duty, Single-Spindle Drink Mixer with Timer



### MAIN FEATURES

- Independent, high-performance, 1 peak HP motor is user-replaceable for continued operation
- Includes thermal protection to prolong motor life
- Electronic, 3-speed and pulse controls maintain speed under load for optimal performance – 15,000 / 18,000 / 21,000 RPM
- Fully enclosed actuators prevent mix from entering the housing
- Each unit includes 2 agitators for each spindle: One solid agitator for mixing hard ice creams and aerating for increased yield, and one butterfly agitator for softer ice creams and mix-ins
- Increased cup clearance: Slide cups into position without tilt
- Fully automatic, cup-activated, one-handed START/STOP operation
- 10-minute timer
- Heavy-duty, powder-coated die-cast steel housing
- Stainless steel malt beverage cup included
- Limited One-Year Warranty

### ELECTRICAL

Voltage: 120  
 Frequency: 50/60Hz  
 Watts: 375  
 Amps: 1.15  
 Plug Type: NEMA 5-15P ⓘ  
 Cord Length: 5 feet



### SALES FEATURES

Enjoy hands-free operation and consistent results with the Waring® WDM120TX Heavy-Duty Single-Spindle Drink Mixer with Timer. Make classic milkshakes and malts your customers will love. Power through the coldest, hardest ice cream with ease, thanks to a 1 peak HP, high-performance motor. A large, easy-to-read LCD display lets you program the timer before or during use to maximize efficiency.

Heavy-Duty, Single-Spindle Drink Mixer with Timer

WDM120TX



@waringcommercial

©2019 Waring Commercial  
 314 Ella T. Grasso Avenue, Torrington, CT 06790  
 Tel. 800-492-7464 • Fax 860-496-9008

waringcommercialproducts.com



# Heavy-Duty, Single-Spindle Drink Mixer with Timer WDM120TX

## PARTS & ACCESSORIES



**CAC20** Stainless Steel Malt Cup



**CAC112** Solid Agitator (6 pack)



**CAC123** Butterfly Agitator (6 pack)

## DIMENSIONS

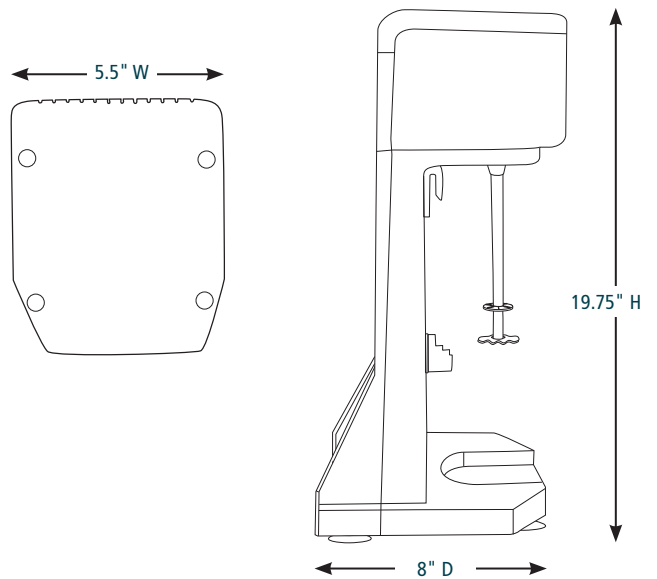
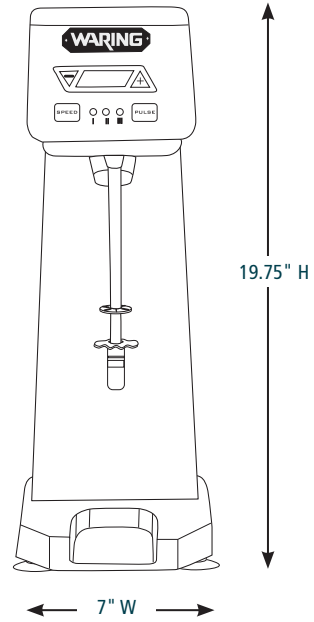

Out of Box Weight: 14.5 lb.

ORDERING INFORMATION	#STD. PKG.	GIFTBOX WEIGHT	CUBIC FEET	BOX DIMENSIONS L X W X H	UPC	CASE PKG.	MC WEIGHT	MC DIMENSIONS L X W X H	MBC
WDM120TX – Heavy-Duty, Single-Spindle Drink Mixer with Timer	1	17.3	1	10.23" x 9.05" x 22"	040072083327	1	18.48	11" x 9.1" x 22.8"	10040072083324



@waringcommercial

©2019 Waring Commercial  
314 Ella T. Grasso Avenue, Torrington, CT 06790  
Tel. 800-492-7464 • Fax 860-496-9008

waringcommercialproducts.com

19WC059594 / REV 08w/19