

VINOA COLLECTION

V-133WDZ



TECHNICAL SPECIFICATIONS

CAPACITY	133 bottles (750 ml)
TEMPERATURE	Upper zone : 41-68 °F (5-20 °C)
2 ZONES	Lower zone : 41-68 °F (5-20 °C)
DIMENSIONS	H 67,71" X W 23,42" X D 27,95" H 1 720 mm X W 595 mm X D 710 mm
PACKAGING DIMENSIONS	H 73,82" X W 25,4" X D 30,07" H 1 875 mm X W 645 mm X D 780 mm
WEIGHT	203 lbs / 92 kg

SPECIFIC FEATURES

DOOR TYPE	Seamless stainless steel frame with double-pane LOW-E glass
HINGES	Black flush-fit hinges
HANDLE	Contemporary handle
SHELVES	10 sliding beech wood shelves 2 beech wood display shelves
CONTROL	LCD touchscreen display
AUTOMATIC LIGHTING	LED lighting with 3 color options (warm white, cool white, blue)
PURIFICATION	Charcoal filter
AIRFLOW SYSTEM	Stainless steel kickplate and silent fan
LOCK	Yes
EVAPORATOR	Copper
COMPRESSOR	Embraco Refrigerant gas: R600a
MOBILITY	Small casters at the back
REVERSIBLE DOOR	Yes
TYPE OF INSTALLATION	Built-in or freestanding
CERTIFICATION	CSA
DOOR OPENING ALARM	Yes



Canadian company



133 bottles



100% extendable shelves



2 zone (41-68 °F)



Quiet (42 dB)



Charcoal filter



LED with 3 color options



Reversible door



Energy-efficient (R-600a)

VINOA COLLECTION

SINCE 1981
CAVAVIN[®]
 WINE CARE SOLUTIONS
 THE ART OF LIVING AT HOME

BUILT-IN INSTALLATION DRAWINGS

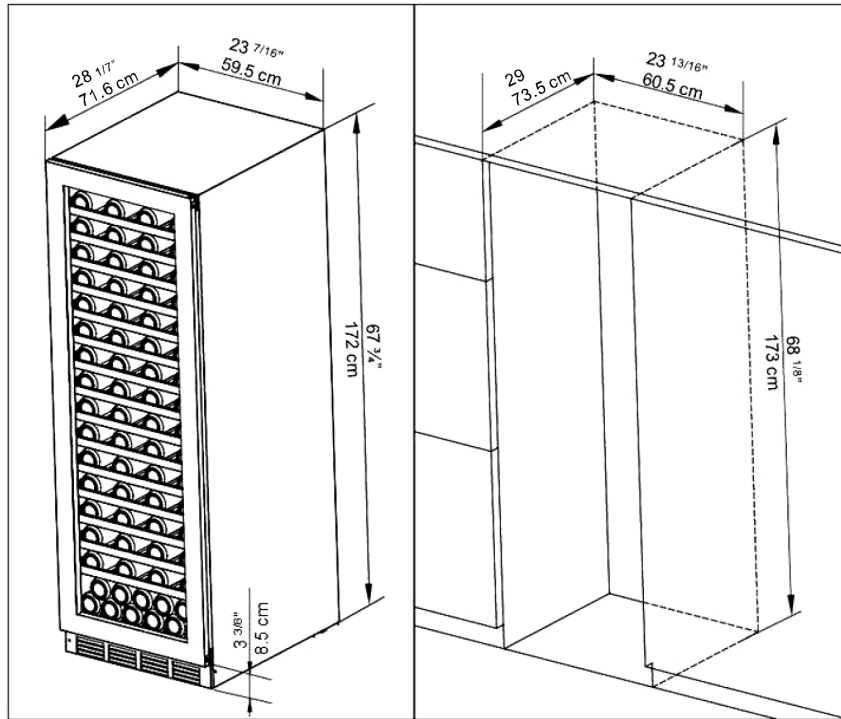

BOTTLE CAPACITY PER SHELF

