

VINOA COLLECTION

V-067WBVC



TECHNICAL SPECIFICATIONS

CAPACITY	21 bottles (750ml) + 46 cans (355ml)
TEMPERATURE	Left zone : 41-68 °F (5-20 °C)
2 ZONES	Right zone : 34-50 °F (1-10 °C)
DIMENSIONS	H 34" X W 23,82" X D 23,62" H 865 mm X W 65 mm X D 600mm
PACKAGING DIMENSIONS	H 36" X W 25,79" X D 26,77" H 914 mm X W 655 mm X D 680 mm
WEIGHT	110 lbs / 50 kg

SPECIFIC FEATURES

DOOR TYPE	Seamless stainless steel frame with double-pane LOW-E glass
HINGES	Black flush-fit hinges
HANDLE	Contemporary handle
SHELVES	9 sliding beech wood shelves + 3 glass plates
CONTROL	LED display
AUTOMATIC LIGHTING	LED lighting with 3 color options (warm white, cool white, blue)
PURIFICATION	Charcoal filter
AIRFLOW SYSTEM	Stainless steel kickplate and silent fan
LOCK	Yes
EVAPORATOR	Copper
COMPRESSOR	Embraco Refrigerant gas: R600a
MOBILITY	Small casters at the back
REVERSIBLE DOOR	No
TYPE OF INSTALLATION	Built-in or freestanding
CERTIFICATION	CSA
DOOR OPENING ALARM	Yes



Canadian company



21 bottles and 46 cans



100% extendable shelves



2 zone (34-68 °F)



Quiet (42 dB)



Charcoal filter



LED with 3 color options



Reversible door



Energy-efficient (R-600a)

VINOA COLLECTION

V-067WBVC

SINCE 1981
CAVAVIN[®]
 WINE CARE SOLUTIONS
 THE ART OF LIVING AT HOME

BUILT-IN INSTALLATION DRAWINGS

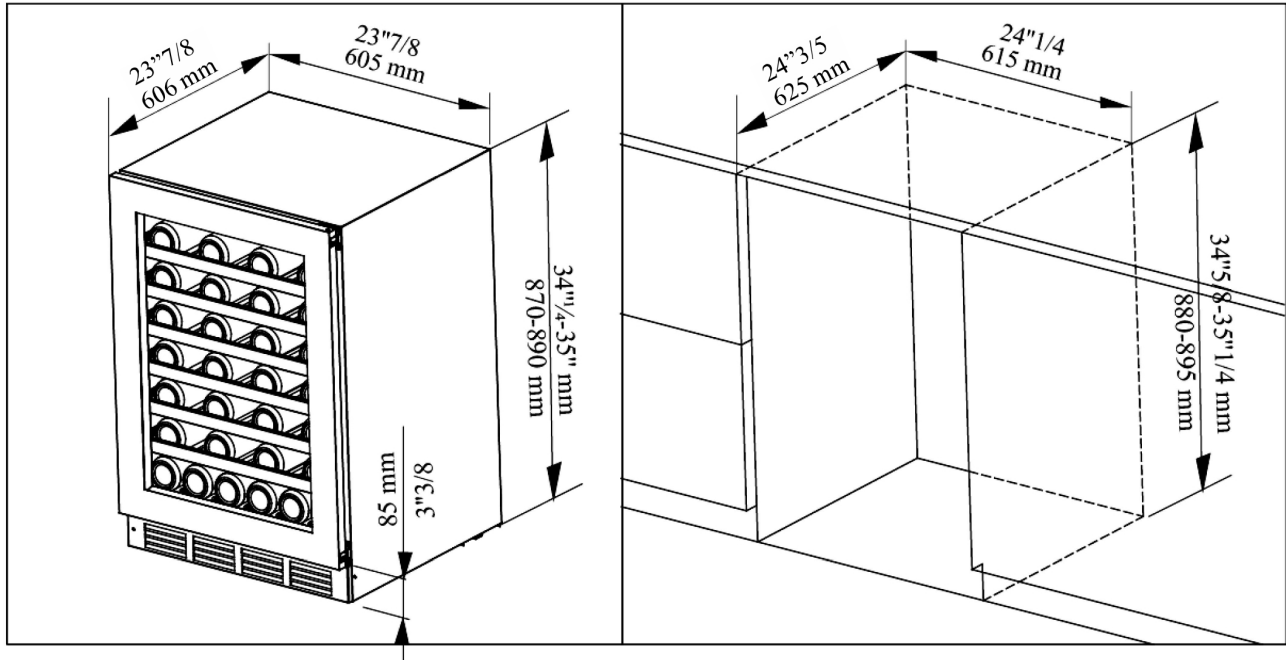

BOTTLE CAPACITY PER SHELF

