

# VINOA COLLECTION

# V-041WBVC



## TECHNICAL SPECIFICATIONS

CAPACITY	41 bottles (750 ml)
TEMPERATURE	Upper zone : 41-58 °F (5-14 °C)
2 ZONES	Lower zone : 34-50 °F (1-10 °C)
DIMENSIONS	H 34,25" X W 23,82" X D 23,62" H 870 mm X W 605 mm X D 600mm
PACKAGING DIMENSIONS	H 36,22" X W 25,79" X D 26,77" H 920 mm X W 655 mm X D 680 mm
WEIGHT	110 lbs / 50 kg

## SPECIFIC FEATURES

DOOR TYPE	Seamless stainless steel frame with double-pane LOW-E glass
HINGES	Black flush-fit hinges
HANDLE	Contemporary handle
SHELVES	4 beech wood shelves on sliding rails + 2 glass plates
CONTROL	LCD touchscreen display
AUTOMATIC LIGHTING	LED lighting with 3 color options (warm white, cool white, blue)
PURIFICATION	Charcoal filter
AIRFLOW SYSTEM	Stainless steel kickplate and silent fan
LOCK	Yes
EVAPORATOR	Copper
COMPRESSOR	Embraco Refrigerant gas: R600a
MOBILITY	Small casters at the back
REVERSIBLE DOOR	Yes
TYPE OF INSTALLATION	Built-in or freestanding
CERTIFICATION	CSA
DOOR OPENING ALARM	Yes



Canadian company



41 bottles



100% extendable shelves



2 zone (41-68 °F)



Quiet (42 dB)



Charcoal filter



LED with 3 color options



Reversible door



Energy-efficient (R-600a)

# VINOA COLLECTION

## V-041WBVC



### BUILT-IN INSTALLATION DRAWINGS

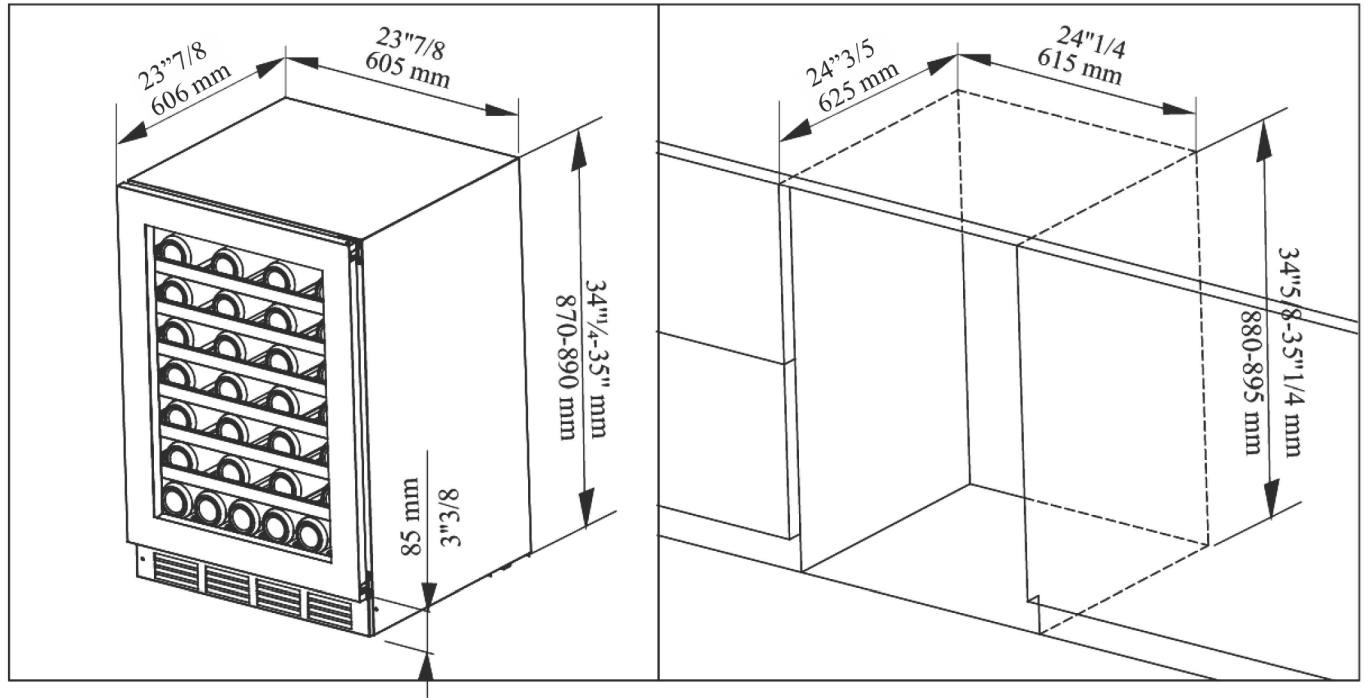

### BOTTLE CAPACITY PER SHELF

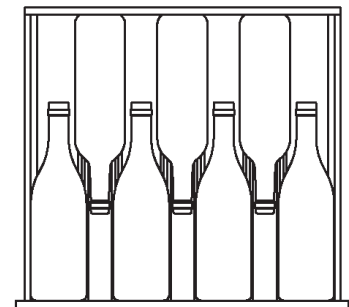
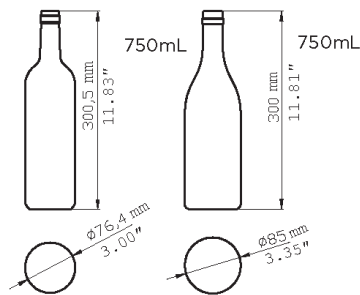
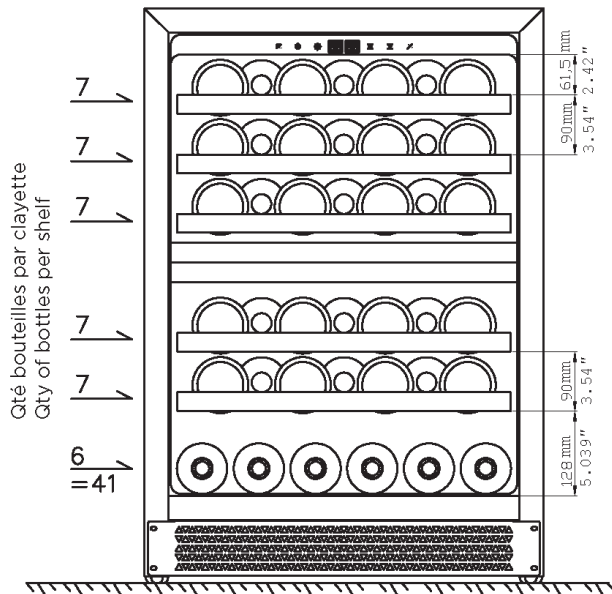

Position des bouteilles  
Clayette en bois  
Bottles position  
Wood shelf