

VINOA COLLECTION

V-024WDZ-V2



TECHNICAL SPECIFICATIONS

CAPACITY	24 bottles (750 ml)
TEMPERATURE	Upper zone : 41-54 °F (5-12 °C)
2 ZONES	Lower zone : 50-68 °F (10-20 °C)
DIMENSIONS	H 34,25" X W 14,96" X D 23,62" H 870 mm X W 380 mm X D 600mm
PACKAGING DIMENSIONS	H 36,22" X W 17,13" X D 26,77" H 920 mm X W 435 mm X D 680 mm
WEIGHT	90 lbs / 41 kg

SPECIFIC FEATURES

DOOR TYPE	Seamless stainless steel frame with double-pane LOW-E glass
HINGES	Black flush-fit hinges
HANDLE	Contemporary handle
SHELVES	5 beech wood shelves on full-extension sliding rails, with a front trim combining wood and stainless steel.
CONTROL	LCD touchscreen display
AUTOMATIC LIGHTING	LED lighting with 3 color options (warm white, cool white, blue)
PURIFICATION	Charcoal filter
AIRFLOW SYSTEM	Stainless steel kickplate and silent fan
LOCK	Yes
EVAPORATOR	Copper
COMPRESSOR	Variable speed compressor, quiet and energy-efficient
MOBILITY	Small casters at the back
REVERSIBLE DOOR	Yes
TYPE OF INSTALLATION	Built-in or freestanding
CERTIFICATION	CSA
DOOR OPENING ALARM	Yes



Canadian company



24 bottles



100% extendable shelves



2 zones (41-68 °F)



Quiet (42 dB)



Charcoal filter



LED with 3 color options



Reversible door



Energy-efficient (R-600a)

VINOA COLLECTION

V-024WDZ-V2



BUILT-IN INSTALLATION DRAWINGS

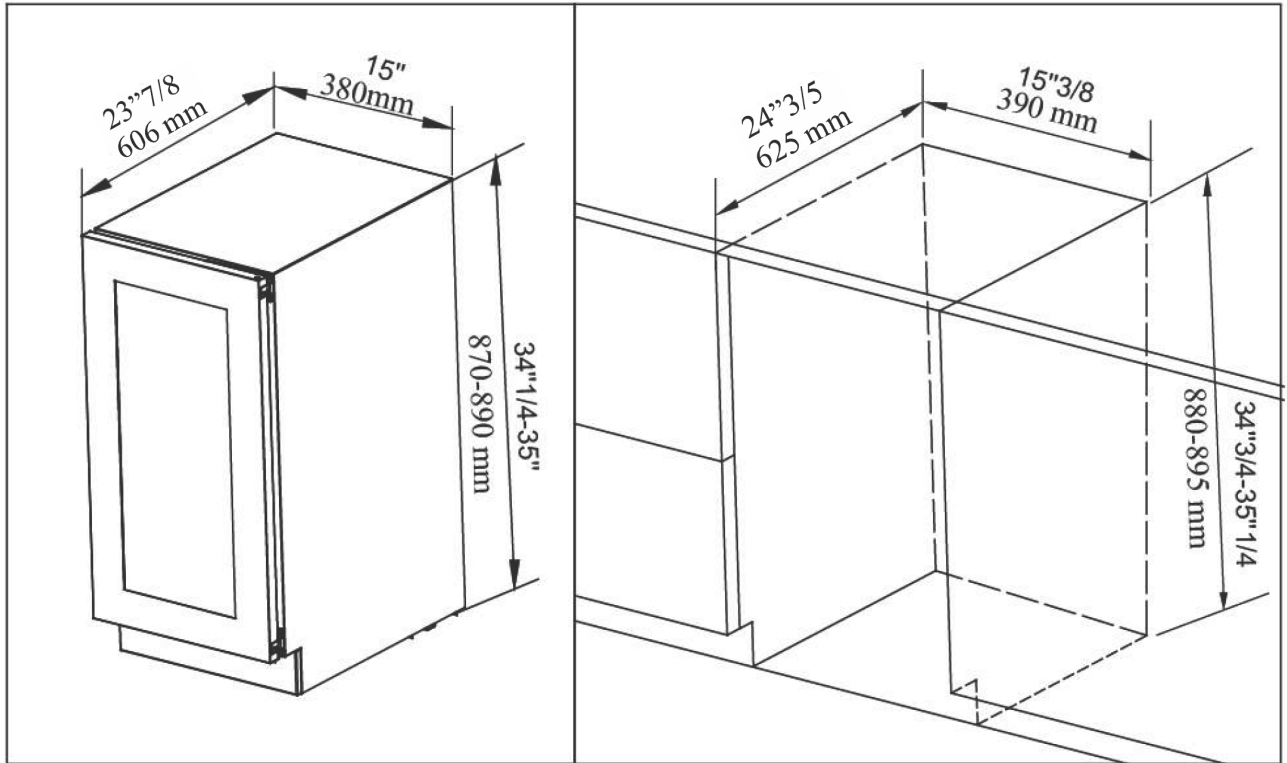

BOTTLE CAPACITY PER SHELF

