

MP 550



Easy Plug



**A** SALES DESCRIPTION

Ideal for blending soups and puréeing fruit and vegetables. Special institutional catering model intended for intensive use

**B** TECHNICAL DESCRIPTION

MP 550 Immersion Blenders. 120V/60/1. Power: 1.2 HP/ 840 W. Speed: 12,000 rpm. 100% stainless-steel blades, bell and shaft (total length: 21"). "Easy Plug" system featuring detachable power cord

**C** TECHNICAL CHARACTERISTICS

Effective output	1.2 HP/ 840 W
Electrical data	120V/60/1 7 amps – plug supplied
Speed	12,000 rpm
Recyclability	95%
Net weight	16 lb
Reference	MP550

**D**

Pan capacity

up to 200 L

▶ Specially designed for intensive use in commercial/institutional catering

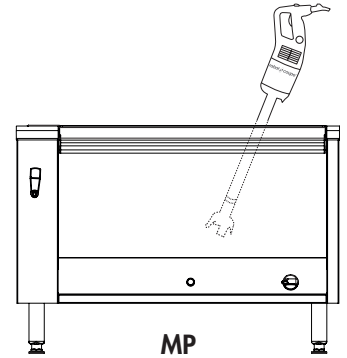

**E** CHARACTERISTICS AND BENEFITS

**MOTOR UNIT**

- Power 1.2 HP/ 840 W
- Stainless-steel motor unit with air vents in the top section to ensure watertightness
- Ridge on motor housing serves as a rest and pivot on the pan rim for greater user comfort
- Speed 12,000 rpm
- New patented "Easy Plug" system making it easier to replace the power cord during after-sales servicing
- Cord winding system for tidy storage and optimum lifespan
- Indicator light to check if the power cord is properly connected

**SHAFT AND BELL**

- 100% stainless-steel blades, bell and shaft (total length: 21").
- Foot with detachable bell and blades (patented system exclusive to Robot Coupe)
- Watertight bell design for optimum lifespan

**STANDARD ATTACHMENTS**

- Wall-mounted Immersion Blenders holder
- Tool for attaching and detaching the blades

**STANDARDS**

ETL electrical and sanitation Listed/ cETL (Canada)



MP 550

MP 550

G

DRAWINGS & DIMENSIONS

120V/60/1 – power cord and plug supplied

