



# VERSACHILL

## FWDW2-27VC

FREEZER 2DW WORKTOP S/S 27in



**WARRANTY:**  
TWO YEAR PARTS AND  
LABOUR; FIVE YEARS ON  
COMPRESSOR

SPECIFICATIONS SUBJECT TO  
CHANGE WITHOUT NOTICE.



### FWDW2-27VC

#### 27 INCH 2 DRAWER WORKTOP FREEZER

- Heavy-gauge Stainless Steel exterior finish
- Clear coated Aluminum Liner
- Adjustable Heavy-Duty Epoxy-coated shelves
- Locking drawers w/ magnetic door gaskets
- Countertop style work space with backsplash
- Automatic defrost system that evaporates defrost water
- Positive Seal self-closing doors w/stay open feature
- Sophisticated Digital Controller to ensure steady temp range from -8 to 0°F (-22 to -17°C)
- Brilliant Interior LED lighting
- Environmentally friendly R290 hydrocarbon refrigerant
- Has temperature preservation & reduces energy consumption design
- Evaporator fan motor conserves energy when door is open
- Inner bottom has round corners for easy cleaning w/ removable gaskets
- Standard EFI Warranty for Refrigeration and freezer units.

#### ADDITIONAL IMAGES



#### MODEL DESIGNATIONS

#### ADDITIONAL RESOURCES



DIMENSIONS

Dimensions	Width		Depth		Height		Weight	
	Inches	mm	Inches	mm	Inches	mm	Lbs	KG
Exterior	27.5	698.0	31.0	787.0	36.9	938.0	147.7	67.0
Shipping	29.3	745.0	31.9	810.0	43.2	1,096.0	179.7	81.5
Interior	23.9	608.0	23.7	601.0	26.7	678.0		

TECHNICAL

Pans	Capacity	Drawers	Casters	HP	Amps	Voltage	Refrig	Plug	Cord len
6	126/4.4	2	2"	1/6	1.5	115	R290	NEMA5-15P	≥1.8m

LINE DRAWINGS

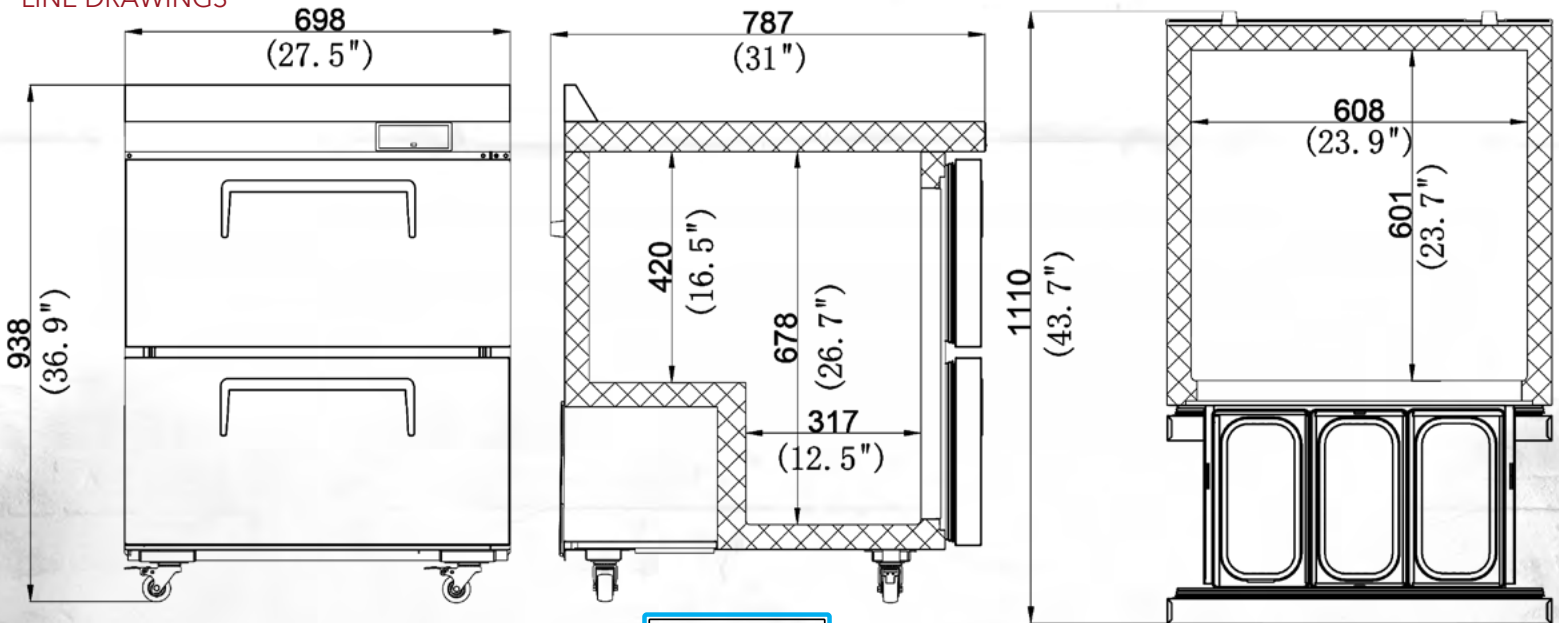

PRODUCT DRAWINGS



NEMA 5-15P



EFI Sales Ltd.  
 Toronto Office & DC  
 515 Hanlon Creek Blvd.  
 Guelph, ON, N1C 0A1

EFI Sales Ltd.  
 Vancouver Office & DC  
 26895 Gloucester Way  
 Langley, BC, V4W 3Y3

(888) 565-9920 Toll Free  
 (519) 822-1895 Toronto  
 (604) 607-8850 Vancouver