

## SteamCub™

34" UNIVERSAL EQUIPMENT STAND\* OPEN TYPE  
STAND, ALL STAINLESS STEEL CONSTRUCTION

Project \_\_\_\_\_  
Item \_\_\_\_\_  
Quantity \_\_\_\_\_  
FCSI Section 11400 \_\_\_\_\_  
Approved \_\_\_\_\_  
Date \_\_\_\_\_

SteamCub™ Boilerless Connectionless Steamer

### Models

- UNISTAND34 (PART # 111721)

FOR:

STEAMCRAFT® ULTRA 3 (21CET8)  
STEAMCRAFT® ULTRA 5 (21CET16)  
STEAMCRAFT® ULTRA 5 (21CGA5)  
STEAMCHEF™ 3 (22CET3.1)  
STEAMCHEF™ 6 (22CET6.1)  
STEAMCUB™ (15CEMCS)  
STEAMCUB PLUS™ (15CE)

Optional Top Cover Kit  
(111728) required  
for mounting one  
SteamCub or  
one SteamCub Plus



Shown with optional:

- Pull-Out Shelf Kit (111724)
- Pan Rack Kit (111726)

### Standard Features

- Holes provided for securing unit into proper position and accommodating utilities
- All stainless steel welded construction with 1 1/4" square tubing
- Stationary shelf provided at bottom of stand
- Adjustable feet (rear feet are flanged for floor bolting)
- Ideal for mounting other kitchen equipment (toasters, slicers, etc.)

Note: Not intended for stacking units.

### Options & Accessories

- Top Cover Kit (111728) for mounting one SteamCub or one SteamCub Plus
- Pull-Out Shelf Kit (111724)
- Pan Rack Kit (111726)
- Stainless Steel Wire Shelves (WS5)
- Stainless Steel Perforated Cafeteria Pans (PP)
- Stainless Steel Solid Cafeteria Pans (SP)

\* Replaces models ES222834 & ES21301

### Short Form Specifications

Shall be a Cleveland 34" Universal Equipment Stand UNISTAND34 (Part # 111721) with: Holes provided for securing unit into proper position and accommodating utilities; All stainless steel welded construction with 1 1/4" square tubing; Stationary shelf at bottom of stand; Adjustable feet (rear feet are flanged for floor bolting).

KE004046-101

## UNISTAND34 EQUIPMENT STAND

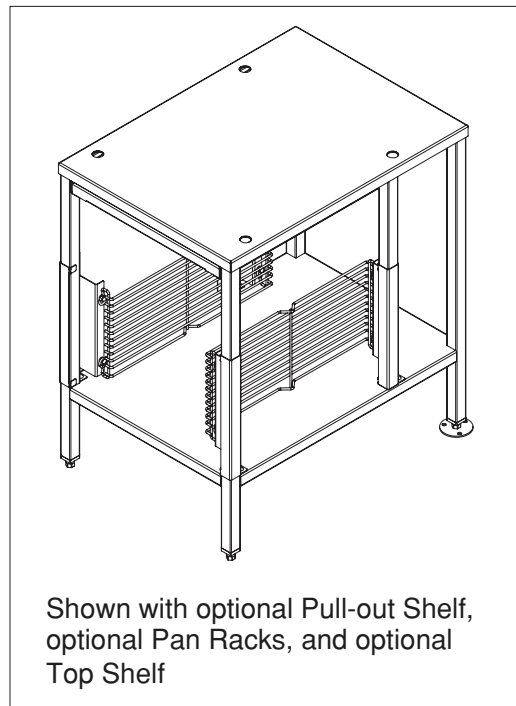
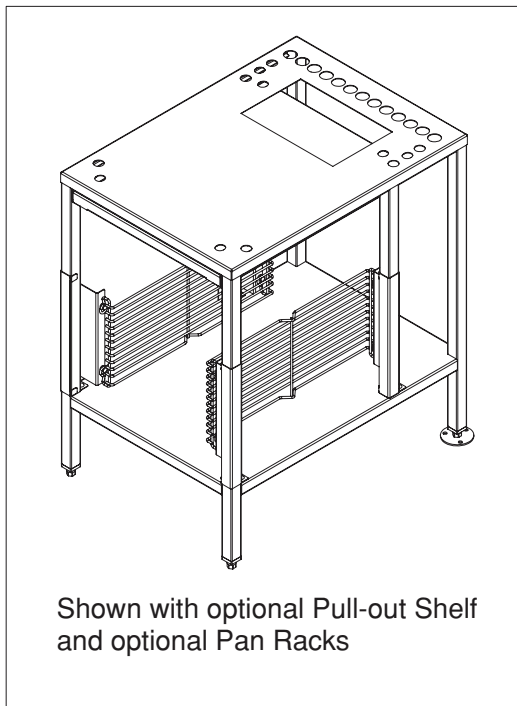
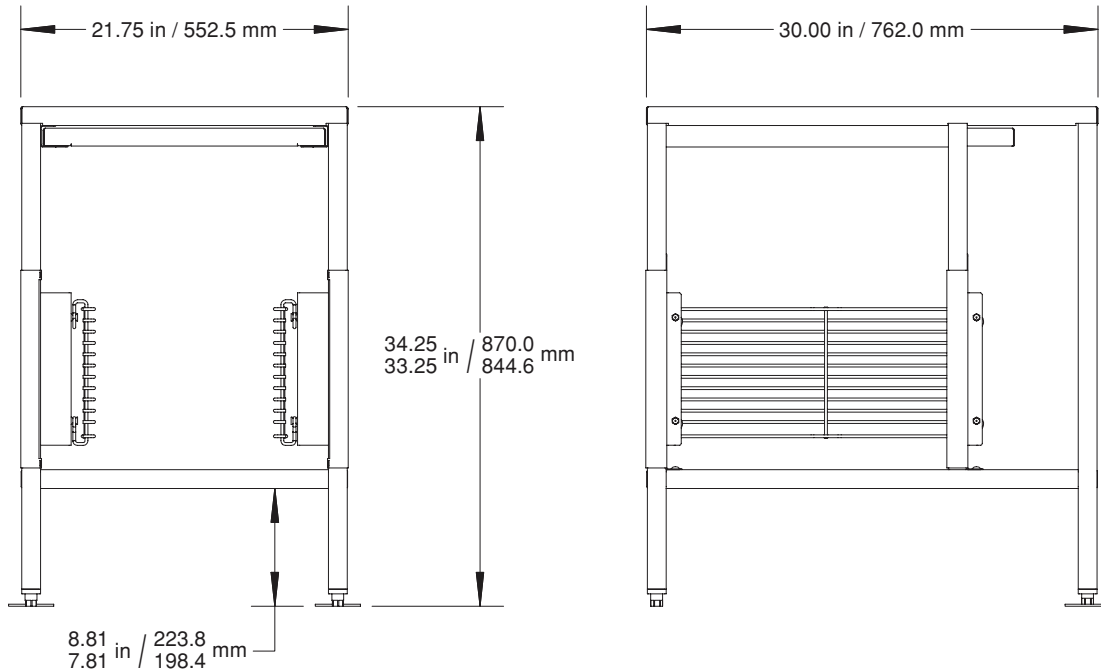

**NOTES:**

Cleveland Range reserves right of design improvement or modification, as warranted.  
 Many regional, state and local codes exist and it is the responsibility of the owner and installer to comply with the codes.  
 Cleveland Range equipment is built to comply with applicable standards for manufacturers. Included among those approval agencies are U.L./NSF#4 and CSA (AGA, CGA).

(NOT TO SCALE)