



**VERSACHILL**

**CCB-60**

**CHEF BASE REFRIGERATED S/S 60in**

**WARRANTY:**  
TWO YEAR PARTS AND  
LABOUR; FIVE YEARS ON  
COMPRESSOR  
  
SPECIFICATIONS SUBJECT TO  
CHANGE WITHOUT NOTICE.

FIND  
ADDITIONAL  
BENEFITS  
HERE



**CCB-60**  
**60 INCH REFRIGERATED**  
**CHEF BASE STAINLESS STEEL**

- Heavy-gauge Stainless Steel exterior finish
- Adjustable Heavy-Duty Epoxy-coated shelves
- Removable and magnetic drawer gaskets for easy cleaning and replacement.
- Gravity-fed self-closing drawers
- Sophisticated Digital Controller to ensure a steady temp range from 33 to 40°F (0 to 4°C)
- Environmentally friendly R290

- Heavy-duty stainless-steel drawer slides and rollers; no tools required for drawer removal
- Automatic defrost system that evaporates defrost water
- hydrocarbon refrigerant
- Has temperature preservation & reduces energy consumption design
- Evaporator fan motor conserves energy when door is open
- Inner bottom has round corners for easy cleaning w/ removable door gaskets
- Standard EFI Warranty for Refrigeration and Freezer Units

ADDITIONAL IMAGES



MODEL DESIGNATIONS

ADDITIONAL RESOURCES



### DIMENSIONS

Dimensions	Width		Depth		Height		Weight	
	Inches	mm	Inches	mm	Inches	mm	Lbs	KG
Exterior	60.4	1,533.0	33.1	840.0	26.8	681.0	233.7	106.0
Shipping	62.4	1,585.0	34.5	875.0	29.6	750.0	296.5	134.5
Interior	40.0	1,015.0	25.6	650.0	16.7	425.0		

### TECHNICAL

Pans	Capacity	Drawers	Casters	HP	Amps	Voltage	Refrig	Plug	Cord len
6	117/4.1	2	4"	1/6	2.8	115	R290	NEMA5-15P	≥1.8m

### LINE DRAWINGS

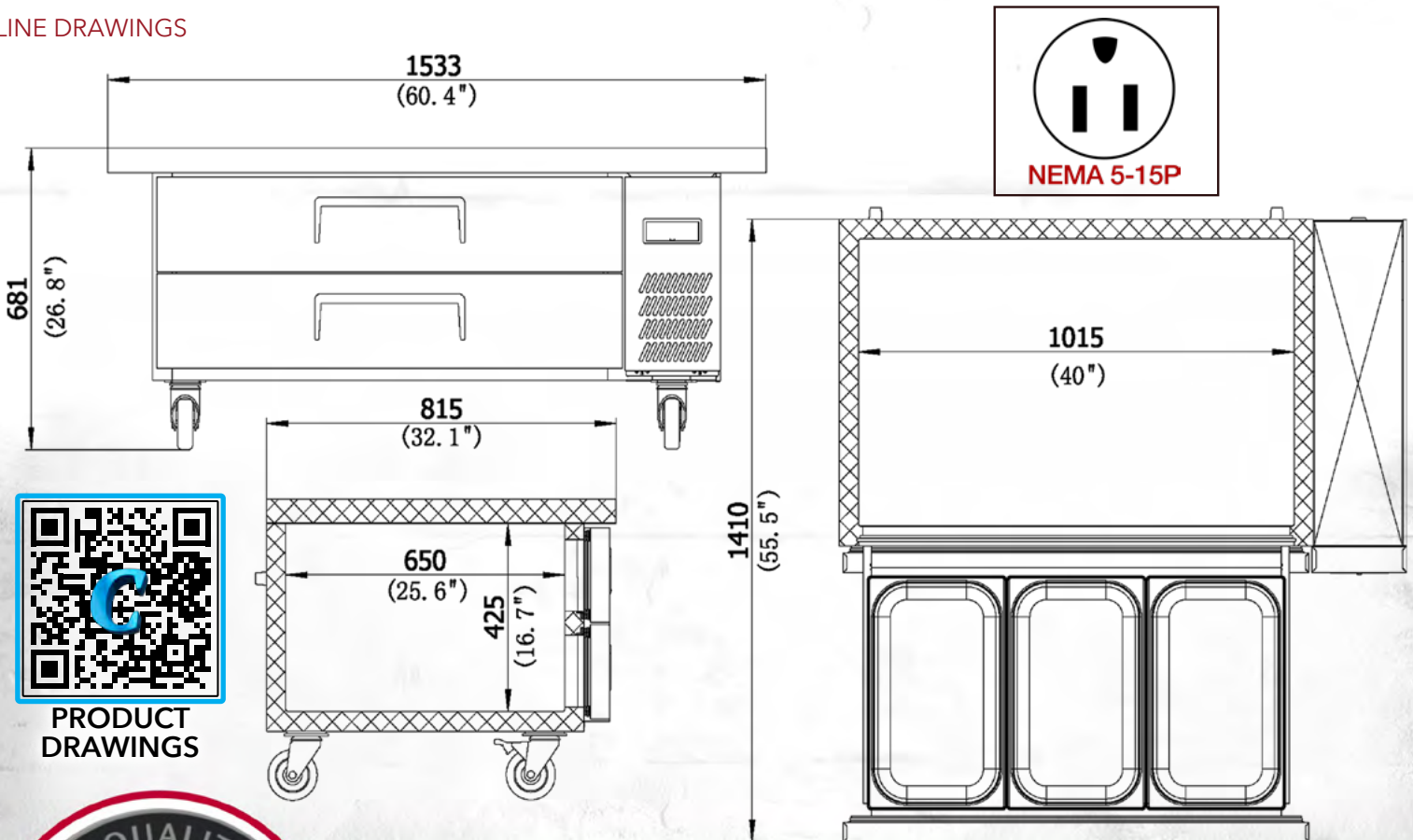

PRODUCT DRAWINGS



EFI Sales Ltd.  
 Toronto Office & DC  
 515 Hanlon Creek Blvd.  
 Guelph, ON, N1C 0A1

EFI Sales Ltd.  
 Vancouver Office & DC  
 26895 Gloucester Way  
 Langley, BC, V4W 3Y3

(888) 565-9920 Toll Free  
 (519) 822-1895 Toronto  
 (604) 607-8850 Vancouver