

G-Series 36" Gas Restaurant Range

Project _____
 Item _____
 Quantity _____
 CSI Section 11400
 Approved _____
 Date _____

Models

- G36-6R • G36-4G12R • G36-2G24R • G36-G36R
- G36-6S • G36-4G12S • G36-2G24S • G36-G36S
- G36-6T • G36-4G12T • G36-2G24T • G36-G36T



Model G36-6R

Standard Features

- Large 27" (686mm) work top surface
- Stainless steel front and sides
- Stainless steel 5" (127mm) plate rail
- Stainless steel backguard, w/ removable stainless steel shelf
- 12" (305mm) section stamped drip trays w/ dimpled bottom
- 6" (152mm) adj. stainless steel legs
- Large phenolic knobs
- Gas regulator
- Easy to access oven pilot
- Reinforced chassis

Standard on Applicable Models:

- Open storage in lieu of oven, (suffix S)
- Modular top (Suffix T) with stainless steel low-profile backguard & 4" (102mm) adj. metal legs
- Ergonomic split cast-iron top ring grates
- 33,000 BTU/9.67 kW 2-piece cast-iron Starfire® open top burner
- 5/8" (15mm) thick steel griddle plate w/ manual hi/lo valve control, 23" (584mm) working depth surface, standard on right, optional on left
- Front-serviceable griddle
- 4-1/4" (108mm) wide grease trough
- 18,000 BTU/5.27 kW cast-iron "H" style griddle burner per 12" (305mm) width of griddle
- 38,000 BTU/ 11.13 kW cast-iron "H" style oven burner
- Snap-action modulating oven

- thermostat low to 500° F
- Nickel-plated oven rack and 3-position removable oven rack guide
- Large porcelain oven interior, fits standard sheet pans in both directions for standard ovens
- Square-cornered door design with strong, "keep-cool" oven door handle

Options & Accessories

- Thermostatic griddle with modulating snap-action control, 175° to 425° F
- Hot top 12" (305mm) plate in lieu of two open burners, manual valve controlled w/ 18,000 BTU/5.27 kW cast-iron "H" burner standard on left side, optional on right
- Low-profile 9-3/8" (238mm) backguard stainless steel front and sides
- Additional oven racks
- Four 6" (152mm) levelling swivel casters w/front locking
- Flanged deck mount legs
- Celsius temperature dials
- Piezo spark ignition for pilots on griddles
- Range mount salamanders and cheesemelters are available for the oven and storage base models only

Specifications

Gas restaurant series range with large capacity standard oven.

35 7/16" (900mm) wide, 27" (686mm) deep worktop surfaces.

Stainless steel front, sides and 5" wide front rail.

6" (152mm) legs with adjustable feet.

Six Starfire® 2-piece, 33,000 BTU/9.67 kW (natural gas), cast-iron open burners set in split cast-iron ergonomic grates.

Griddle or optional hot top with cast-iron "H" style burners, 18,000 BTU/5.27 kW (natural gas), in lieu of open burners.

Porcelain oven interior.

Heavy-duty cast-iron "H" oven burner rated 38,000 BTU/11.13 kW (natural gas)

Oven controlled by even bake, fast recovery snap-action modulating oven thermostat.

Available with storage base or modular top model in lieu of oven.

NOTE: Use only Garland certified casters and approved restraining devices.



G-Series 36" Gas Restaurant Range

G-Series 36" Gas Restaurant Range

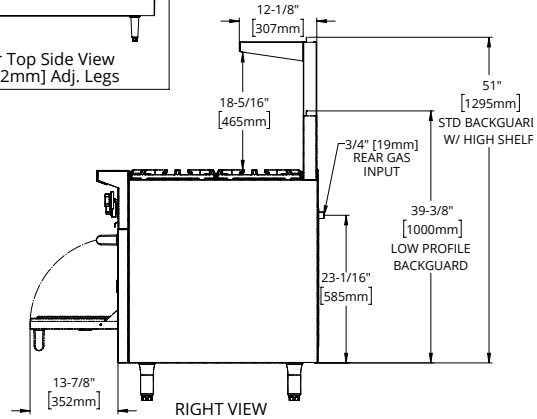
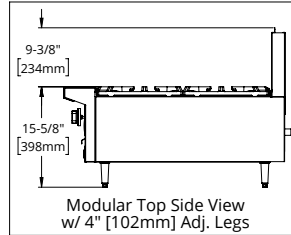
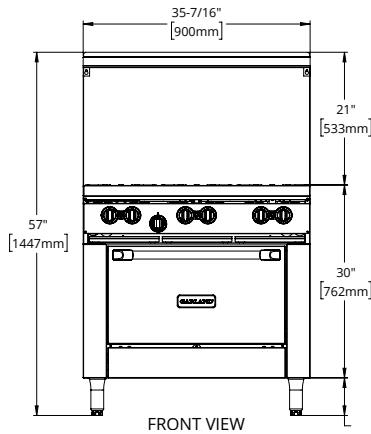
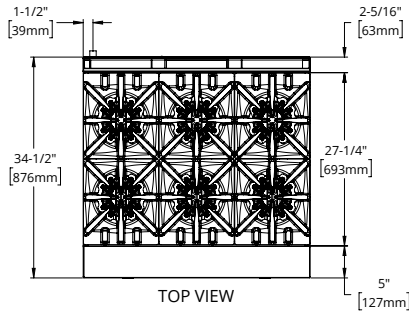

Gas input ratings shown for installations up to 2000 ft., (610m) above sea level. Please specify altitudes over 2000 ft.

This product is not approved for residential use.

Note: Installation clearance reductions are applicable only where local codes permit.

Model Number	Description	Total BTU/Hr Natural	Shipping Information	
			Lbs/Kg	Cu Ft
G36-6R	Six OB w/26" Oven	236,000	430/195	40
G36-6S	Six OBs w/SB	198,000	310/141	40
G36-6T	Six OB MT	198,000	190/86	22
G36-4G12R	12" G, Four OB w/26" Oven	188,000	460/209	40
G36-4G12S	12" G Four OB w/SB	150,000	340/154	40
G36-4G12T	12" G Four OB MT	150,000	220/100	22
G36-2G24R	24" G, Two OB w/26" Oven	140,000	495/225	40
G36-2G24S	24" G Two OB w/SB	102,000	375/170	40
G36-2G24T	24" G Two OB MT	102,000	255/116	22
G36-G36R	36" G w/26" Oven	92,000	530/240	40
G36-G36S	36" G w/SB	54,000	410/186	40
G36-G36T	36" G MT	54,000	290/132	22

Burner Ratings (BTU/Hr/kW)		
Burner	Natural	Propane
Open	33,000/9.67	30,000/8.79
Griddle/Hot Top	18,000/5.27	18,000/5.27
Oven	38,000/11.13	32,000/9.38

Manifold Operating Pressure	
Natural	Propane
4.5" WC 11 mbar	10.0" WC 25 mbar

OB = Open Burner, SS = Space Saver
SB = Storage Base, MT = Modular Top, G = Griddle

Model Type	Width	Depth	Height w/shelf	Oven Interior		
				Height	Depth	Width
Range Base	35-1/2" (900mm)	34-1/2" (876mm)	57" (1448mm)	13" (330mm)	26" (660mm)	26-1/4" (667mm)
Modular Top	35-1/2" (900mm)	34-1/2" (876mm)	25" (654mm)*	N/A	N/A	N/A

*w/ low-profile backguard

Model Type	Combustible Wall Clearance		Entry Clearances	
	Sides	Rear	Crated	Uncrated
Range Base	14" (356mm)	6" (152mm)	37" (940mm)	36-1/2" (927mm)
Modular Top	14" (356mm)	6" (152mm)	16" (406mm)	12" (305mm)

Garland reserves the right to make changes to the design or specifications without prior notice.

Garland Commercial Ranges Ltd.
1177 Kamato Road,
Mississauga, Ontario
L4W 1X4 CANADA

General Inquires 1-905-624-0260
USA Sales, Parts and Service 1-800-424-2411
Canadian Sales 1-888-442-7526
Canada or USA Parts/Service 1-800-427-6668

www.garland-group.com
8069B
01/26

