



FOOD EQUIPMENT

### Easy Tomato Slicer™

55600-1      3/16" Slice

55600-2      1/4" Slice

55600-3      3/8" Slice

55600-7      7/32" Slice

## Operating and Maintenance Instructions

### Important / Recommendations

1. To get the best operation and life from your machine, please read and comply with these instructions.  
**NOTE: Proper Cleaning and maintenance plays an important part in the life span and functioning of the unit**
2. Caution – **SHARP BLADES** – use care when handling the Blade Assembly.
3. **Tomato Slicer is intended ONLY to cut tomatoes**, hard or dense produce (like an onion) will cause damage to the blade and pusher.
4. **Clean machine thoroughly before first use and after each use following the cleaning instructions below.**
5. **Cleaning – wash blades after each use.** Acid from the tomatoes will attack the stainless steel blade if not washed off, causing premature dulling.
  - a. **Clean, rinse and sanitize.** Be sure to read and follow sanitizer manufacturer instructions. Sanitizer must be food safe and safe for use with Aluminum, Stainless and HDPE plastics
  - b. **Caution – DO NOT** use chlorine based cleaners to sanitize as the chlorine will attack the stainless steel blade and cause pitting and corrosion.
  - c. Minimize the use of alkaline cleaners as they may cause pitting and dulling of the finish.
6. Wash with a brush and mild detergent and water. Wash Blades with brush from back side (non Sharp Side). **IMPORTANT** - The use of a brush is required to properly clean the Tomato Slicer.
7. NEMCO recommends occasional application of mineral oil in the grooves of the slide board to help the pusher to continue to slide smoothly. **Important** - DO NOT USE ANY TYPE OF COOKING OIL – The GUIDE PLATE will seize up on the SLIDE BOARD.

### Safety instructions

1. **Caution: blades are VERY SHARP; use extreme caution when cleaning the blades**
2. **Use careful handling to keep hands away from the blades when cleaning or operating the machine.**
3. Do not operate with GUARDS missing or removed.

### Operation

1. If the Tomato Slicer fails to work properly when first operated call NEMCO customer service at 1-800-782-6761.
2. Your Tomato Slicer comes assembled and ready to use. You may want to install the TABLE STOP for your convenience.
3. Set the Tomato Slicer on a flat surface.
4. Pull HANDLE all the way toward you and carefully place the tomato on the SLIDE BOARD between the PUSHER PLATES and the BLADES. **CAUTION: SHARP BLADES**
5. Withdraw your hand. With one quick motion, push the HANDLE toward the BLADES and catch the tomato in your hand or container.
6. Remove the sliced tomato from the SLIDE BOARD and repeat the procedure for the next tomato to be sliced.

## **Cleaning**

**Caution: SHARP BLADES!!**

***Clean machine thoroughly after each use.***

1. To remove the PUSHER ASSEMBLY for cleaning, remove the THUMB SCREWS and the SLIDE STOP and pull the PUSHER off the end of the SLIDE BOARD.
2. Wash with a brush using soap or mild detergent and water.
3. Immediately after cleaning, a sanitizer may be used. Be sure to read and follow sanitizer manufacturer instructions. Sanitizer must be food safe and safe for use with Aluminum, Stainless and HDPE plastics.
4. To re-assemble, reverse the procedure.
5. **NOTICE:** Always rinse the TOMATO SLICER in cold or lukewarm water after it has been washed in hot water! (Hot water will make the SLIDE BOARD expand and may make it hard to push the PUSHER ASSEMBLY until the SLIDE BOARD returns to room temperature.)
6. **Caution:** If Pusher Assembly or Tomato Slicer is dropped, this may cause Pusher Assembly misalignment with the Blade Assembly. After cleaning, be sure the Pusher Assembly properly passes through the Blade Assembly.

## **Service Instructions**

1. When placing BLADES into the TENSION BLOCKS, place one TENSION BLOCK on the worktable with the long groove turned up and the other TENSION BLOCK with the long groove turned down. Insert a blade (sharp side down) in the end slot of each TENSION BLOCK and push a TENSION ROD into each TENSION BLOCK and push a TENSION ROD into each TENSION BLOCK just far enough to secure the BLADE. Insert another blade in the next slot and push the TENSION ROD to secure it. Repeat until all BLADES are in place.
2. When placing BLADES into the BLADE HOLDER, be sure the sharp side of the BLADES is pointing toward the caution warning on the BLADE HOLDER.
3. The BLADE KIT can be installed only one way; the mounting screw holes in the TENSION BLOCKS nearest the end of the BLOCK must be down toward the SLIDE BOARD. (If sharp edges of the BLADES point the wrong way, turn the BLADE KIT end for end.)
4. To secure the BLADE ASSEMBLY in the BLADE HOLDER install the (2) hex head screws through the BLADE HOLDER and into the TENSION BAR at the end of the BLADE HOLDER nearest the warning. Tighten these 2 screws "finger tight" or a little tighter. Then install the (2) hex head screws loosely into the TENSION BAR at the other end of the BLADE HOLDER. (Do not tighten the BLADES until after the BLADE HOLDER is mounted on the FRAME.)
5. When mounting the BLADE HOLDER ASSEMBLY on the FRAME, be sure the sharp side of the BLADES is directed toward the PUSHER ASSEMBLY.

## **To Tension Blades**

Tension on the BLADES must be restored after every dis-assembly for cleaning or replacement of the BLADE KIT. To do this:

1. Be sure BLADE HOLDER ASSEMBLY is firmly mounted on the FRAME with the warning and the sharp side of the BLADES toward the PUSHER ASSEMBLY.
2. Be sure the hex head screws on the right side of the BLADE HOLDER (end with CAUTION SHARP BLADES) are tight.
3. Tighten the hex head screws on the left end of the BLADE HOLDER until the BLADES "hum" when plucked. Gradually tighten the top and bottom screws until the top and bottom blades sound about the same when plucked or "strummed".

**NOTICE:** Check the Tension of the BLADES each time the machine is used to be sure they are tight. If not, tighten per (3) above.

**TO REPLACE BLADES** Instructions for BLADE replacement are provided with each BLADE KIT.

**IMPORTANT:** NEMCO recommends occasional application of mineral oil in the grooves of the slide board.

# 55600- ( ) EASY TOMATO SLICER

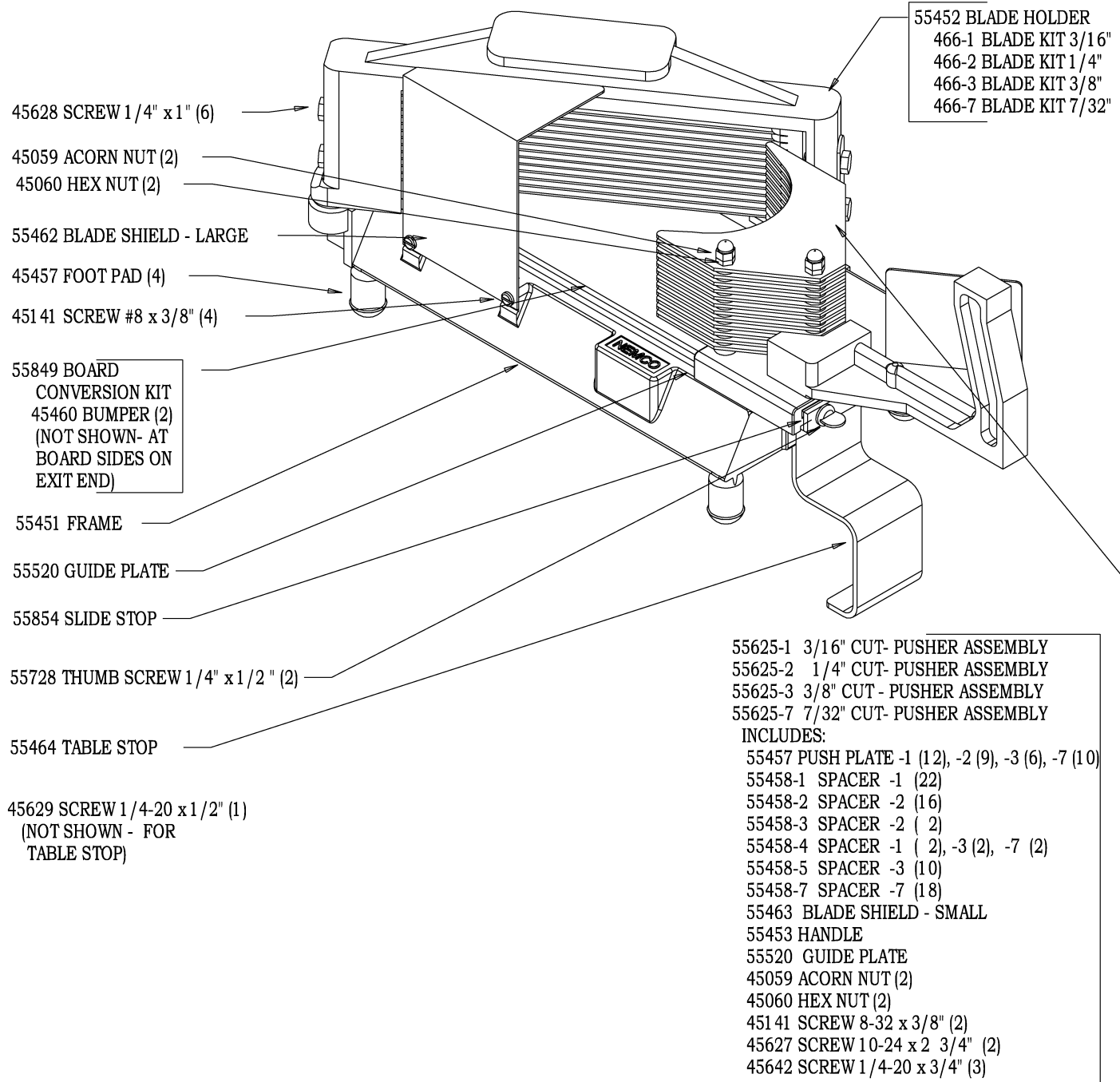

**NEMCO FOOD EQUIPMENT**

Phone: (419) 542-7751

Fax : (419) 542-6690

[www.nemcofoodequip.com](http://www.nemcofoodequip.com)

301 Meuse Argonne, Hicksville, OH 43526

Toll Free: 1-800-782-6761

46023  
2-16-13